

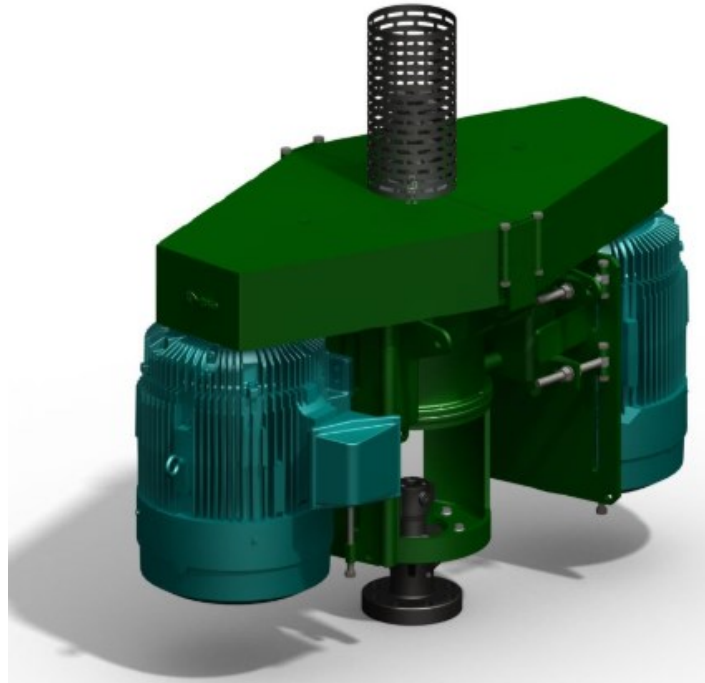

PRO SERIES-B DIRECT DRIVE HEADS



	PRO-75-B				PRO-125-B				PRO-150-B				PRO-250-B			
Max Operating Torque	1750	ft-lbs	2363	N-m	2200	ft-lbs	2983	N-m	2650	ft-lbs	3593	N-m	3500	ft-lbs	4750	N-m
Max Input Power	75	hp	56	kW	125	hp	93	kW	150	hp	112	kW	250	hp	187	kW
Max Motor Frame Size	NEMA 405T or IEC 250M				NEMA 445T or IEC 280M				2x NEMA 405T or IEC 250M				2x NEMA 445T or IEC 280M			
Thrust Bearing Rating - ISO	238000	lbf	1060	kN	310000	lbf	1380	kN	310000	lbf	1380	kN	360000	lbf	1600	kN
Thrust Bearing Rating - Ca90	61800	lbf	275	kN	80400	lbf	358	kN	80400	lbf	358	kN	93000	lbf	415	kN
Sheaved Speed Range	100-500			rpm	100-500			rpm	100-500			rpm	100-500			rpm
VFD Speed Range	50-600			rpm	50-600			rpm	50-600			rpm	50-600			rpm
Polished Rod Size	1.25/1.5	in	31.8/38.1	mm	1.25/1.5	in	31.8/38.1	mm	1.25/1.5	in	31.8/38.1	mm	1.25/1.5	in	31.8/38.1	mm
Weight (Booth Style)	1225	lbs	557	kg	1250	lbs	567	kg	1550	lbs	705	kg	1625	lbs	738	kg
Braking Device	Centrifugal				Centrifugal				Centrifugal				Centrifugal			
Stuffing Box Connection	3-1/8 3k R31 Flange, 4-1/16 3k R37, 5-1/8 2k R41, 5-1/8 3k R41															

